



API 526
SAFETY VALVES 800 Class

Figure

E804.12



DIMENSIONS & WEIGHT of E804

Size inc.	Orifice	L mm	H1 mm	H2 mm	Wt kg
1/2" x 1"	C	35	55	150	0.8
1"x1 1/2"	D	50	70	190	1.4
1 1/2"x2"	E	65	90	250	3

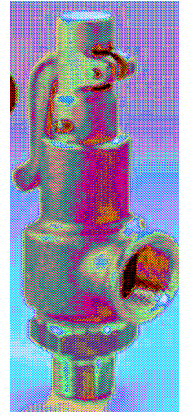

MAX. WORKING PRESSURE	
-29+38 °C	140 BAR
+425 °C	76 BAR

PART LIST for Material No.12			
Item	PART NAME	Symb.	material
1	BODY	A105	ASTM A105
1a	BODY PART	WCB	ASTM A216 Gr.WCB
1b	CAP	CS	CARBON STEEL
2a	SEAT FACE	304	AWS 304
3	DISC	304	AISI 304
3a	DISC FACE	304	INTEGRAL
4	STEM	Cr13	ASTM A182 Gr.F6
4a	SPRING	302	AISI 302
4b	WASHER	ST	STEEL
11	STEM BUSHING	ST	STEEL
11a	BUSHING NUT	B	ASTM A307 B

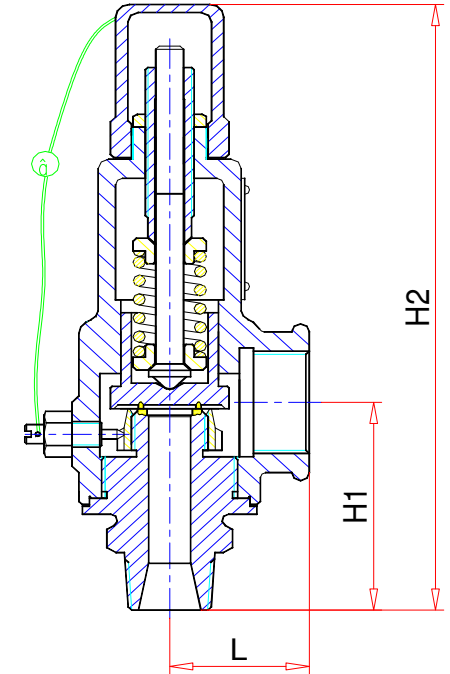
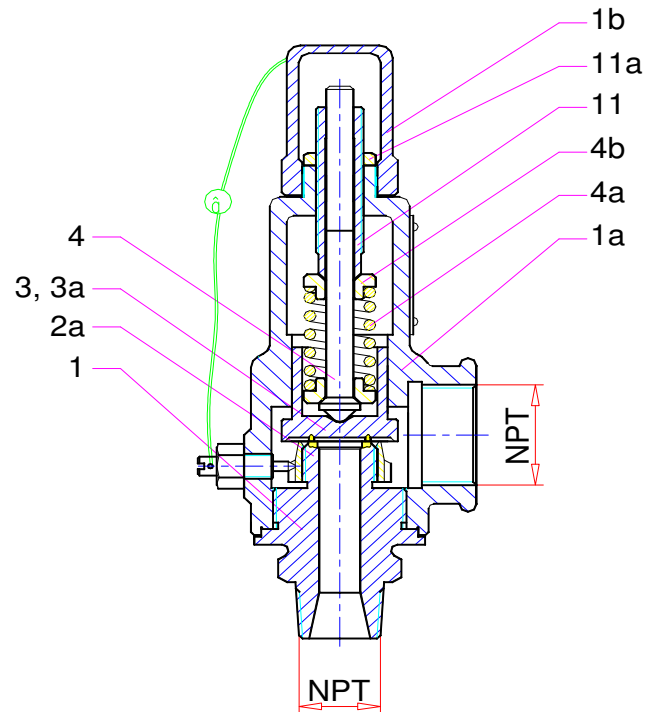

DESIGN STD: ASME & API 526		END TYPE: NPT (M & F)		MAT'L ID.: A105			
Prep.:K.KORKMAZ	Che.:Ş.KOÇAK	Appr.:N.ERGIN	Rev.No / Date:R0 / 08.12.2006	Description:	Datasheet Nr.:E804.12	Attach.	Page&Scale:1/1 A4