



**PN150** Acc. to ISO 17292 STANDARD **800 Class**  
**FORGED STEEL EXTENDED BALL VALVES**  
 FLOATING BALL, FULL BORE, SOFT SEATED, FIRE SAFE, ASD

Figure

**E604P.12**



**DIMENSIONS & WEIGHT of E604P**

NPS	DN	ID	L	L2	H	W	Wt
inc.	mm	mm	mm	mm	mm	mm	Kg
1/2	15	12.5	80	195	65	150	1.5
3/4	20	17	95	210	72	150	2
1	25	23	115	235	80	170	3
1 1/2	40	37	135	255	105	240	6
2	50	49	155	280	114	240	12

	TEST PRESSURE	WORKING PRESSURE
SHELL	225 Bar	-29+100 °C 150 Bar
CLOSURE	150 Bar	

**PART LIST for Material No.12**

Item	PART NAME	Symb.	material
12	ANTISTATIC DEVICE	SS	SPRING+BALL
11	GLAND	304	ASTM A182 Gr.304
10	STEM SEALING	PTFE	Polytetrafluoroethylene
9	GASKET	GRF	GRAPHITE
8	NUT	2H	ASTM A194 Gr.2H
7	WRENCH	St	STEEL
6	PACKING	GRF	GRAPHITE
5	STEM	304	ASTM A182 Gr.304
4	BODY INSERT	A105	ASTM A105
3	BALL	304	ASTM A182 Gr 304
2	SEAT INSERT	PTFE	Polytetrafluoroethylene
1	BODY	A105	ASTM A105

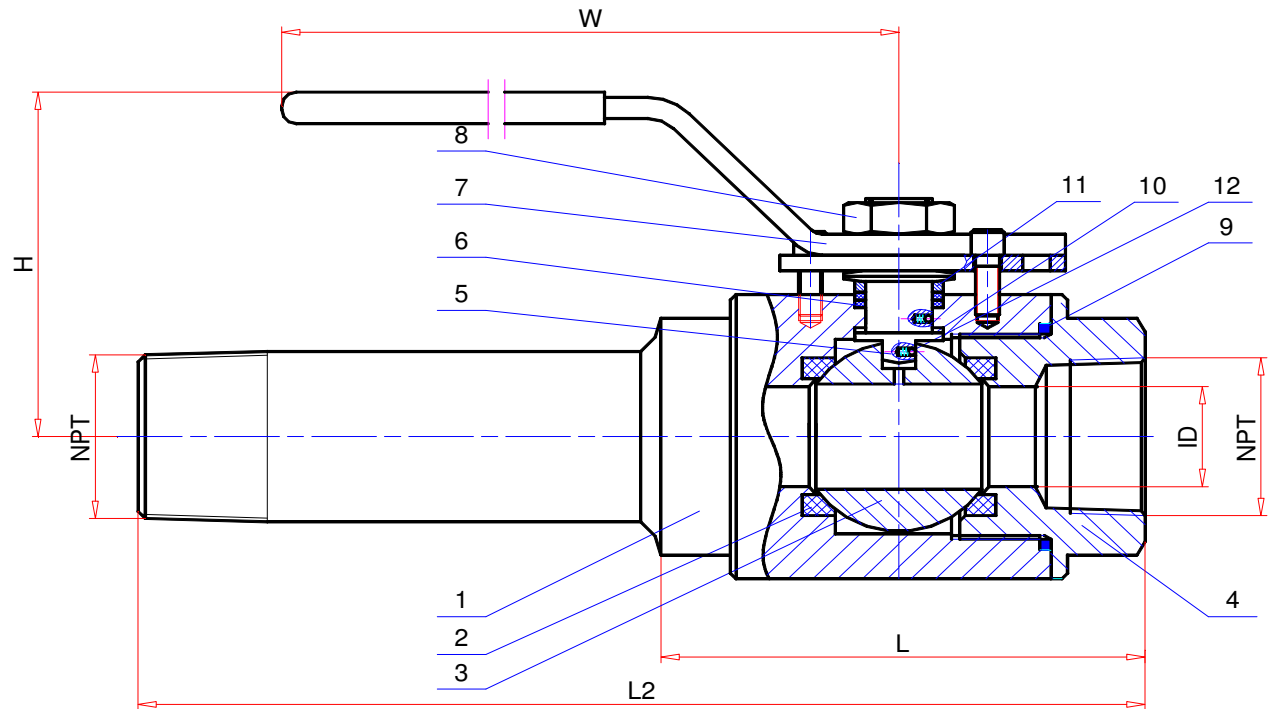

DESIGN STD.: **ASME B16.34** TEST STD.: **ISO 5208** END TYPE: **MNPT - FNPT (Male & Female NPT)** MAT'L ID.: **A105** TRIM ID.: **304+PTFE**

Prep.K.KORKMAZ Che.:U.ÖZDEMİR Appr.:N.ERGIN Rev.No / Date:R0 / 20.08.2006 Description: Datasheet Nr.:E604P.12 Attach. Page&Scale:1/1 A4 Origin:DES