

**b**

**API 6D & ISO 14313 STANDARD**  
**Cast Steel 600 Class CONDUIT GATE VALVES PN 100**  
*Double Block & Bleed, Full Bore, Metal to Metal Seal, Bolted Bonnet, Rising Stem*

Figure

**E54.12****DIMENSIONS ( mm ) & WEIGHT**

DN	D	b	g	K	n	l	L	H	W	Wt	
inch.	mm	mm	mm	mm	no	mm	mm	mm	mm	kg	
4"	100	273	38	157	216	8	26	432	550	600	180
6"	150	356	48	216	292	12	29	559	700	600	260
8"	200	419	56	270	349	12	32	660	900	600	350
10"	250	508	64	324	432	16	35	787	1050	600	550
12"	300	559	67	381	489	20	35	838	1150	600	740
14"	350	603	70	413	527	20	38	889	1270	600	1000
16"	400	686	76	470	603	20	41	991	1400	600	1350
18"	450	743	83	534	654	20	45	1092	1505	600	1650
20"	500	813	89	584	724	24	45	1194	1700	600	2400
24"	600	940	102	692	838	24	51	1397	2100	600	3800
26"	650	1015	108	749	914	28	51	1448	2300	600	4800
28"	700	1075	111	800	965	28	54	1549	2600	600	5500
30"	750	1130	114	857	1022	28	54	1651	3000	600	6100
32"	800	1195	117	914	1080	28	60	1778	3300	600	7800
34"	850	1245	121	965	1130	28	60	1930	3650	600	8550
36"	900	1315	124	1022	1194	28	60	2083	4000	600	9200
42"	1050	1405	168	1168	1283	32	67	2286	4380	600	11000
48"	1200	1595	189	1334	1460	32	73	2438	4800	600	15000

**PART LIST for Material No.18**

Item	PART NAME	Symb.	material
1	Body	WCB	ASTM A216 Gr.WCB
1a	Bonnet	WCB	ASTM A216 Gr.WCB
2	Body Seat Ring	ST	ASTM A515
2a	Seat Ring Face	316	AWS ER316
3	Gate	WCB	ASTM A216 Gr.WCB
3a	Gate Seat Face	316	AWS ER316+BUNA_N
4	Stem	316	ASTM A182Gr.F316
6	Packing	TFE	TEFLON
12	Yoke	ST	ASTM A515
12b	Bolt	B	ASTM A307.B
12c	Bolt	B	ASTM A307.B
13	Gasket	GRF	GRAPHITE
13a	Segment	ST	ASTM A515
13b	Bonnet Nut	ST	ASTM A515
17	Handwheel	ST	STEEL
17b	Gear Box	AR	MASTERGEAR
17d	Stem Indicator	PVC	PLASTIC
18	Name Plate	AL	ALUMINIUM
19	Paint	AL	ALUMINIUM
19a	End Cover	W	WOODEN CAP.

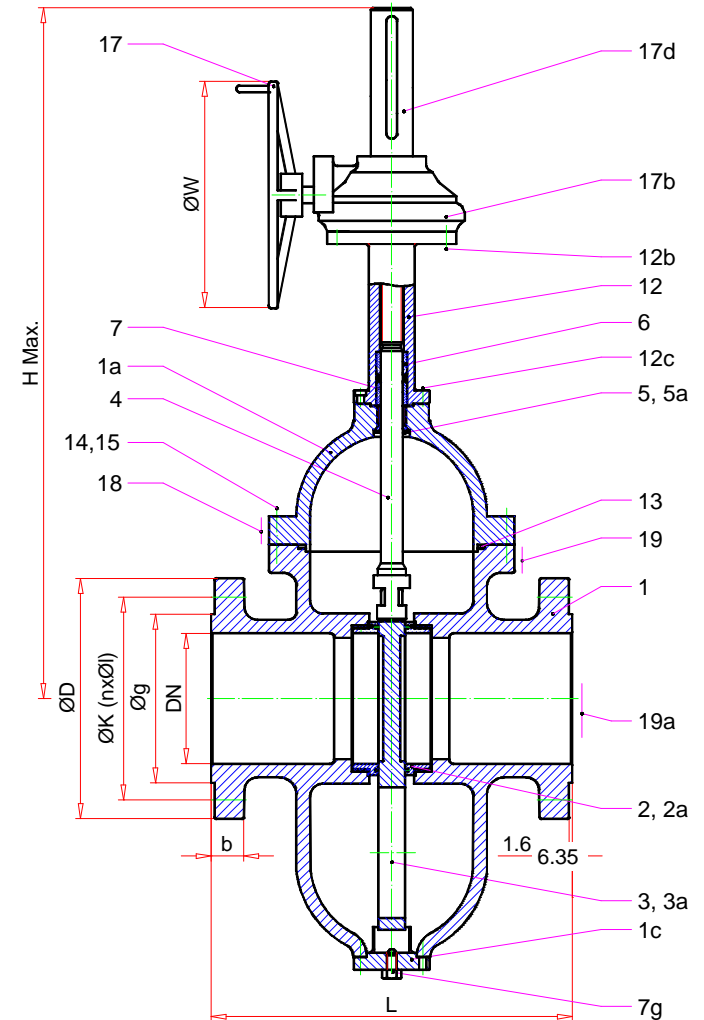

TEST PRESSURE		WORKING PRESSURE	
Shell & Backseat	153 Bar	-29+38 °C	102 Bar
Closure	112 Bar	Max. 200 °C	88 Bar
Air	6 Bar		

DESIGN STD: API 6D & ISO 14313	FACE to FACE STD.: ANSI B16.10	FLGD STD.: ANSI B16.5 & ISO 7005-PN110	MAT'L ID:WCB	TRIM ID:316-Buna N
Prep.:K.KORKMAZ	Che.:S.KOÇAK	Appr.:N.ERGIN	Rev.No / Date:R4 / 20.11.2005	Description:
Datasheet No.:E54.12		Attach.	Page&Scale:1/1 A4	Origin:DES