



300 Class API 600 STANDARD **PN50**
Bolted Bonnet Steel WEDGE GATE VALVES
 OUTSIDE SCREWED & YOKE, RISING STEM, FIRE SAFE

Figure **E520GE.11**



600-0043

DIMENSIONS & WEIGHT of E520

DN	ID	ØD	b	Øg	ØK	n	ØI	L	H	Wt	Kv
inc.	mm	mm	mm	mm	mm	no	mm	mm	mm	kg	
14"	337	585	54	413	514	20	32	762	1785	817	10600
16"	387	648	57	470	572	20	35	838	1980	1039	14000
18"	438	711	61	534	629	24	35	914	2295	1460	17000
20"	489	775	64	584	686	24	35	991	2460	1798	21000
24"	591	915	70	692	813	24	41	1143	2900	2366	30500
28"	686	1035	75	800	940	44	28	1346	3500	2916	42500
30"	737	1090	78	857	997	48	28	1397	3620	3901	50000
32"	781	1150	82	914	1054	51	28	1524	3770	4835	55000
36"	876	1270	88	1022	1168	54	32	1727	4150	6085	70000
42"	1020	1290	94	1137	1206	44	32	1911	5000	8185	95000
48"	1166	1465	102	1308	1372	51	32	2050	5900	10085	124000

	TEST PRESSURE	WORKING PRESSURE
Shell&Backseat	77 Bar	-29+38 °C 51 Bar
CLOSURE	56 Bar	+425 °C 29 Bar
AIR	6 Bar	

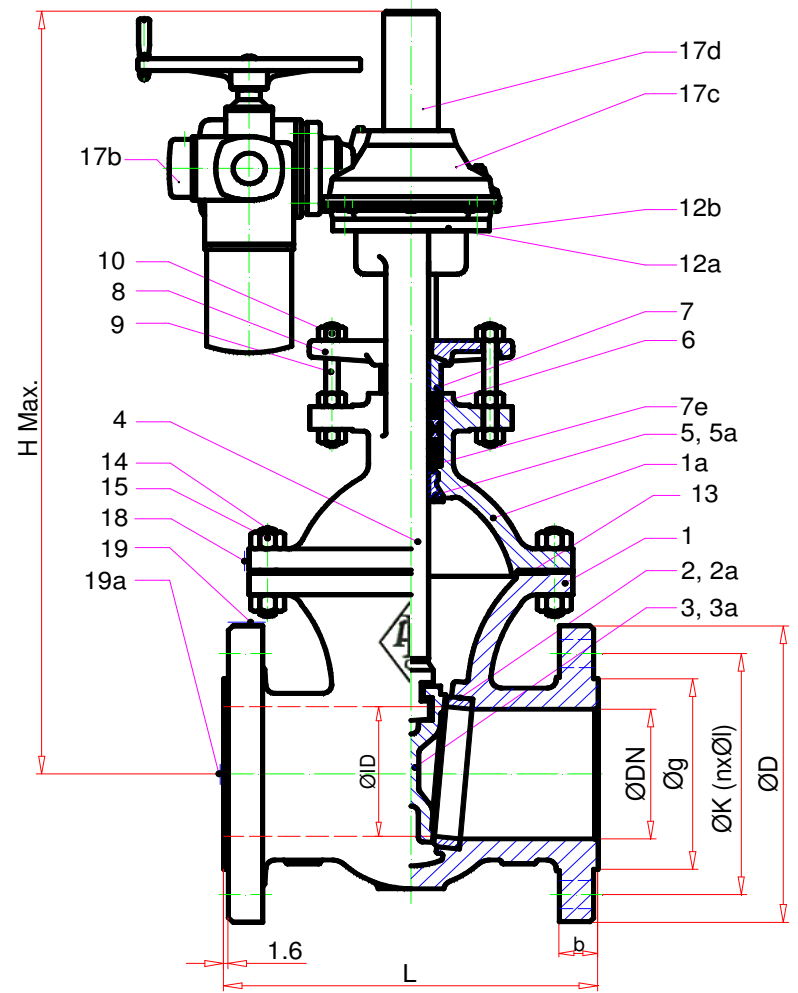

PART LIST for Material No.11

Item	PART NAME	Symb.	material	Item	PART NAME	Symb.	material
1	BODY	WCB	ASTM A216 Gr.WCB	9	GLAND BOLT	B	ASTM A307.B
1a	BONNET	WCB	ASTM A216 Gr.WCB	10	GLAND NUT	B	ASTM A307.B
2	BODY SEAT RING	ST	ASTM A105	12a	FLANGE	ST	STEEL
2a	Body Seat FACE	Cr13	AWS ER420	12b	BOLT	B	ASTM A307.B
3	WEDGE (*)	WCB	ASTM A216 Gr.WCB	13	GASKET	SWG	304+GRAPHITE
3a	Wedge Seat FACE	Cr13	AWS ER420	14	STUD BOLT	B7	ASTM A193 Gr.B7
4	STEM	Cr13	ASTM A276 T.410	15	NUT	2H	ASTM A194 Gr.2H
5	BACK RING	Cr13	ASTM A276 T.410	17b	ELECTRIC ACTUATOR		
5a	Back Ring FACE		INTEGRAL	17c	GEAR BOX		
6	PACKING	GRF	GRAPHITE	17d	STEM INDICATOR	ST	STEEL
7	GLAND	CR13	ASTM A276 T.410	18	NAME PLATE	SP	STAINLESS PLATE
7e	WHASHER	ST	STEEL	19	PAINT	EP	EPOXY
8	GLAND FLANGE	WCB	ASTM A216 Gr.WCB	19a	END COVER	PVC	PLASTIC

(*) Material CR13 (ASTM A217 Gr.CA15) for 8" smaller