



**300 Class** API 600 STANDARD **PN50**  
**Bolted Bonnet Steel WEDGE GATE VALVES**  
 OUTSIDE SCREWED & YOKE, RISING STEM, FIRE SAFE

Figure

**E520G.11**



600-0043

**DIMENSIONS & WEIGHT of E520**

DN	ID	ØD	b	Øg	ØK	n	ØI	L	H	Wt	Kv
inc.	mm	mm	mm	mm	mm	no	mm	mm	mm	kg	
2"	51	165	23	92	127	8	19	216	465	30	240
2½"	64	191	25	105	149	8	22	241	520	39	350
3"	76	210	29	127	168	8	22	283	555	49	540
4"	102	254	32	157	200	8	22	305	655	88	970
6"	152	318	37	216	270	12	22	403	900	152	2200
8"	203	381	41	270	330	12	26	419	1140	241	3900
10"	254	445	48	324	387	16	29	457	1400	435	6000
12"	305	521	51	381	451	16	32	502	1575	590	8700
14"	337	585	54	413	514	20	32	762	1785	765	10000
16"	387	648	57	470	572	20	35	838	1980	987	14500
18"	438	711	61	534	629	24	35	914	2295	1408	16300
20"	489	775	64	584	686	24	35	991	2460	1746	23500
24"	591	915	70	692	813	24	41	1143	2900	2275	35900
28"	686	1035	75	800	940	44	28	1346	3500	2825	42500
30"	737	1090	78	857	997	48	28	1397	3620	3810	50000
32"	781	1150	82	914	1054	51	28	1524	3770	4660	55000
36"	876	1270	88	1022	1168	54	32	1727	4150	5910	70000
42"	1020	1290	94	1137	1206	44	32	1911	5000	8010	95000
48"	1166	1465	102	1308	1372	51	32	2050	5900	9830	124000

	TEST PRESSURE	WORKING PRESSURE
Shell&Backseat	77 Bar	-29+38 °C 51 Bar
CLOSURE	56 Bar	+425 °C 29 Bar
AIR	6 Bar	

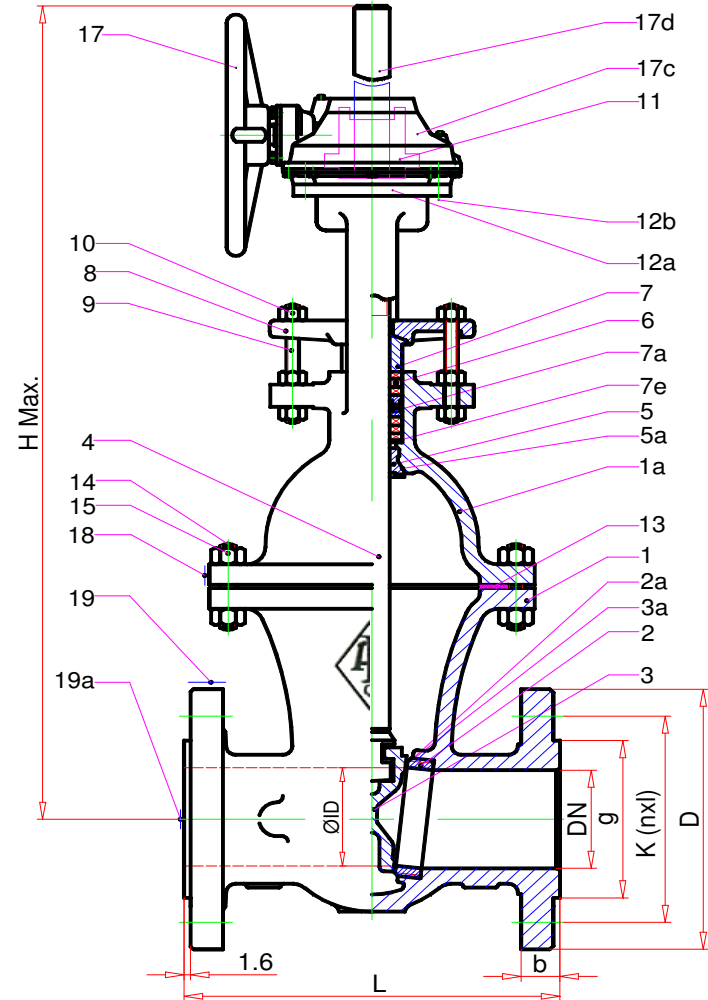

**PART LIST for Material No.11**

Item	PART NAME	Symb.	material	Item	PART NAME	Symb.	material
1	BODY	WCB	ASTM A216 Gr.WCB	10	GLAND NUT	B	ASTM A307.B
1a	BONNET	WCB	ASTM A216 Gr.WCB	11	STEM BUSHING	BZ	ASTM B148
2	BODY SEAT RING	ST	ASTM A105	12a	FLANGE	ST	STEEL
2a	Body Seat FACE	Cr13	AWS ER420	12b	BOLT	B	ASTM A307.B
3	WEDGE (*)	WCB	ASTM A216 Gr.WCB	13	GASKET	SWG	304+GRAPHITE
3a	Wedge Seat FACE	Cr13	AWS ER420	14	STUD BOLT	B7	ASTM A193 Gr.B7
4	STEM	Cr13	ASTM A276 T.410	15	NUT	2H	ASTM A194 Gr.2H
5	BACK RING	Cr13	ASTM A276 T.410	17	HANDWHEEL	DI	ASTM A536
5a	Back Ring FACE		INTEGRAL	17c	GEAR BOX	ST	CARBON STEEL
6	PACKING	GRF	GRAPHITE	17d	STEM PROTECTION	AL	ALUMINIUM
7	GLAND	CR13	ASTM A276 T.410	18	NAME PLATE	SP	STAINLESS PLATE
7e	WHASHER	ST	STEEL	19	PAINT	EP	EPOXY
8	GLAND FLANGE	WCB	ASTM A216 Gr.WCB	19a	END COVER	PVC	PLASTIC
9	GLAND BOLT	B	ASTM A307.B				

(\*) Material CR13 (ASTM A217 Gr.CA15) for 8" smaller

DESIGN STD.: API 600 & ASME B16.34

FACE to FACE STD.: ANSI B16.10 & ISO 5752-T4

FLANGE STD.: ANSI B16.5 & ISO 7005-PN50

MAT'L ID.: WCB

TRIM ID.: Cr13-Cr13-Cr13

Prep.:T. AKYÜREK

Che.:K.KORKMAZ

Appr.:N.ERGIN

Rev.No / Date:R6 / 01.04.2009

Description:

Doc No.:E520G.11-9R0

Attach.

Page&Scale:1/1 A4

Origin:DES