



150 Class

API 600 STANDARD

PN20

**Bolted Bonnet Steel WEDGE GATE VALVES**

Figure

**E510P.11**



600-0043

OUTSIDE SCREWED & YOKE, RISING STEM, FIRE SAFE

**DIMENSIONS & WEIGHT of E510**

DN inc.	ID mm	ØD mm	b mm	Øg mm	ØK mm	n no	ØI mm	L mm	H mm	Kv m <sup>3</sup> /h
2"	51	152	16	92	121	4	19	178	440	240
2½"	64	180	17,5	105	139,7	4	19	191	500	350
3"	76	190	19	127	152	4	19	203	550	520
4"	102	230	24	157	191	8	19	229	670	970
5"	127	255	24	186	216	8	22	254	830	1500
6"	152	280	26	216	241	8	22	267	980	2150
8"	203	345	29	270	299	8	22	292	1200	3850
10"	254	406	30	324	362	12	26	330	1550	6000
12"	305	485	32	381	432	12	26	356	1750	8600
14"	337	535	35	413	476	12	29	381	1950	10600
16"	387	600	37	470	540	16	29	406	2250	14000
18"	438	635	40	534	578	16	32	432	2600	17000
20"	489	700	43	584	635	20	32	457	2750	21000
24"	591	815	48	692	749	20	35	508	3250	30500

**WORKING PRESSURE**

-29+38 °C	20 Bar
+425 °C	6 Bar

**TEST PRESSURE**

SHELL & BACKSEAT	30 Bar
CLOSURE	22 Bar
AIR	6 Bar

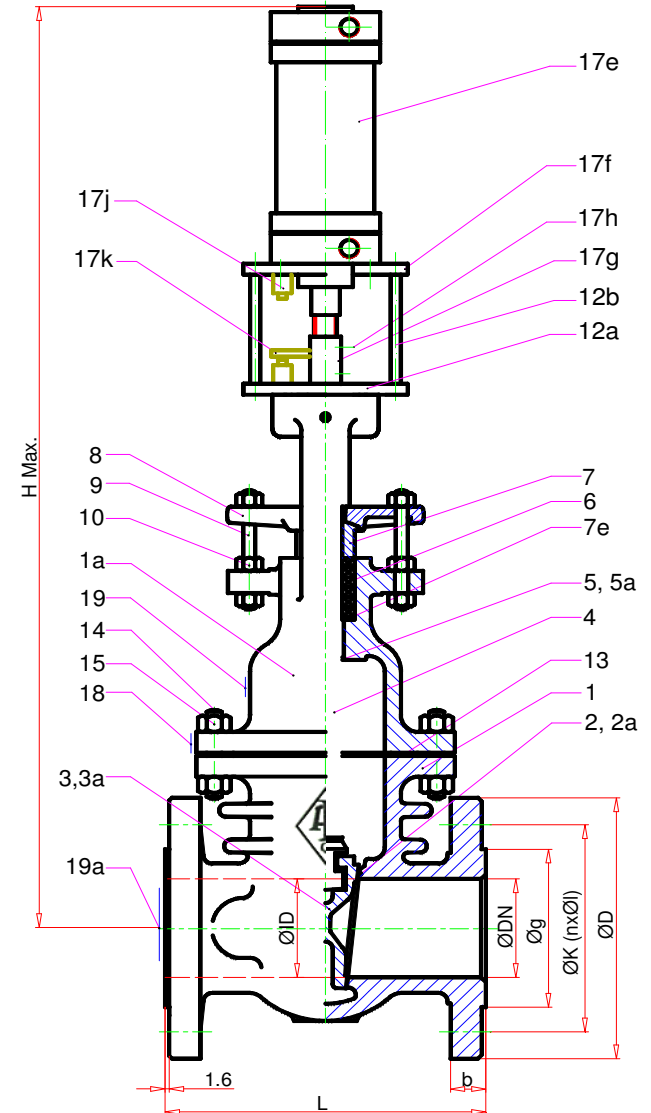

PART LIST for Material No.11							
Item	PART NAME	Symb.	material	Item	PART NAME	Symb.	material
1	BODY	WCB	ASTM A216 Gr.WCB	12a	FLANGE	ST	STEEL
1a	BONNET	WCB	ASTM A216 Gr.WCB	12b	BOLT	B	ASTM A307.B
2	BODY SEAT RING	ST	ASTM A105	13	GASKET	NASF	Non Asbestos S.Fb.
2a	Body Seat FACE	Cr13	AWS ER420	14	STUD BOLT	B7	ASTM A193 Gr.B7
3	WEDGE (*)	WCB	ASTM A216 Gr.WCB	15	NUT	2H	ASTM A194 Gr.2H
3a	Wedge Seat FACE	Cr13	AWS ER420	17e	PNEUMATIC CYLINDER		
4	STEM	Cr13	ASTM A276 T.410	17f	ADAPTOR	ST	STEEL
5	BACK RING	Cr13	ASTM A276 T.410	17g	COUPLING	ST	CARBON STEEL
5a	Back Ring FACE	INTEGRAL		17h	SETSCREW	ST	CARBON STEEL
6	PACKING	GRF	GRAPHITE	17j	LIMIT SWITCH		
7	GLAND	CR13	ASTM A276 T.410	17k	INDICATOR	ST	STEEL
7e	WHASHER	ST	STEEL	18	NAME PLANT	SP	STAINLESS PLATE
8	GLAND FLANGE	WCB	ASTM A216 Gr.WCB	19	PAINT	EP	EPOXY
9	GLAND BOLT	B	ASTM A307.B	19a	END COVER	PVC	PLASTIC
10	GLAND NUT	B	ASTM A307.B				

(\*) Material CR13 (ASTM A217 Gr.CA15) for 8" and smaller