



Acc. to API 602 STANDARD
COMPACT CHECK VALVES 800 Class
 BOLTED BONNET

Figure

E404.11
E404S.11



DIMENSIONS & WEIGHT of E404

NPS	DN	SW	B	L	H	Wt
inc.	mm	mm	mm	mm	mm	kg
1/2	15	21.7	10	73	88	1.6
3/4	20	27.1	13	80	89	1.8
1	25	33.7	13	100	110	3
1 1/4	32	42.6	13	120	140	5.2
1 1/2	40	48.6	13	120	158	7.8
2	50	61.1	16	140	190	11

	TEST PRESSURE	WORKING PRESSURE
SHELL	207 Bar	-29+38 °C
CLOSURE	138 Bar	+425 °C

PART LIST for Material No.11

Item	PART NAME	Symb.	material
1	BODY	A105	ASTM A105
1a	BONNET	A105	ASTM A105
2a	BODY SEAT FACE	CR13	AWS 430
3	DISC	CR13	ASTM A182 Gr.F6
3a	DISC SEAT FACE	INT	INTEGRAL
3b	SPRING	SS	430
13	GASKET	SWG	304-GRAPHITE
14	BONNET BOLT	B7	ASTM A193 Gr.B7
18	NAME PLATE	AL	ALUMINIUM

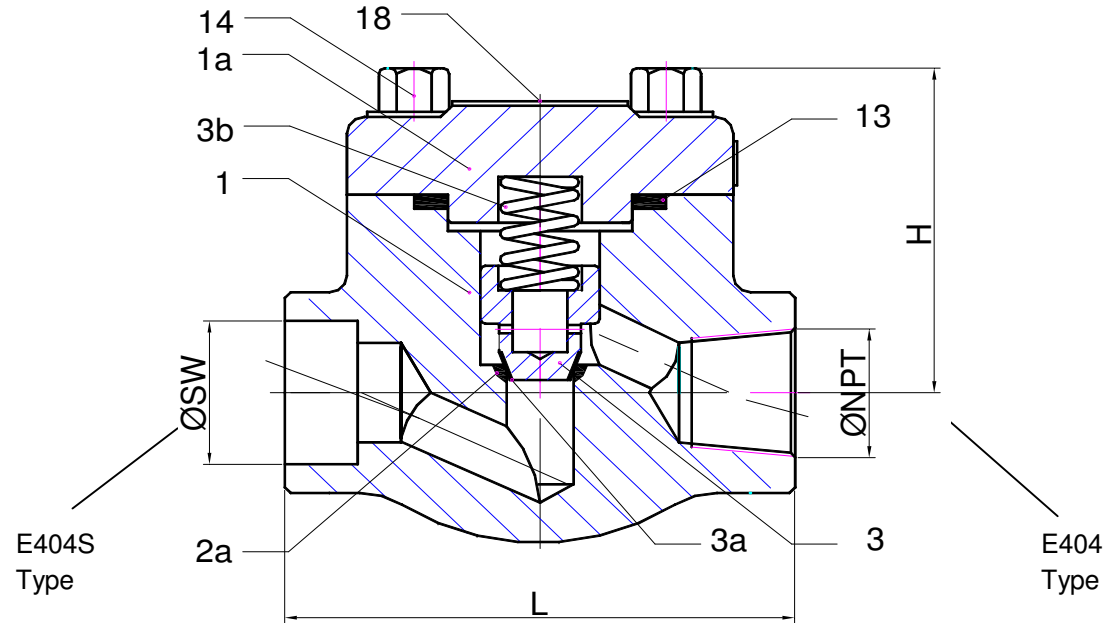

DESIGN STD.: API 602 TEST STD.: API 598 End to End STD.: API 602 END TYPE: NPT or SW MAT'L ID.: A105 TRIM ID.: CR13

Prep.:K.KORKMAZ	Che.:U.ÖZDEMİR	Appr.:N.ERGIN	Rev.No / Date:R4 / 18.11.2007	Description:	Datasheet Nr.: E404S.11	Attach.	Page&Scale:1/1 A4	Origin:DES
-----------------	----------------	---------------	-------------------------------	--------------	-------------------------	---------	-------------------	------------